

MORE AT WWW.VOLTPOLSKA.PL

MANUAL

Ver. 2024-02-09

PURE SINE WAVE VOLTAGE INVERTER

12V DC to 230V AC

24V DC to 230V AC

Models in series: SINUS 600, SINUS 1000, SINUS 1600, SINUS 2000, SINUS 3000,
SINUS 4000, SINUS 5000



VOLT
POLSKA

VOLT POLSKA SP. Z O.O.
ul. Świebrowska 3
81-877 Sopot

pomoc@voltpolska.pl | hurt@voltpolska.pl | (58) 500 85 62

INTRODUCTION

SINUS voltage inverter should be used to power electrical appliances requiring 230V from 12V or 24V (depending on the selected voltage version) batteries and automotive installations. It can be successfully used as an emergency power source for devices requiring continuous power supply, such as furnaces or CO pumps. The distinguishing feature of the **SINUS** inverters from the classic simple AC/DC inverters is pure sine wave sinusoidal alternating output voltage identical to that present in mains in building. **SINUS** inverters can be used as power supply for devices equipped with electric motors and transformers, such as power tools, pumps or low-power household appliances. Simple and inexpensive inverters mostly produce close to rectangular voltage, sometimes mistakenly called approximated sinus wave. This kind of voltage signal is not suitable for inductive or capacitive devices and may cause damage. Using our **SINUS** inverters you can be 100% sure that output voltage is pure sine wave.

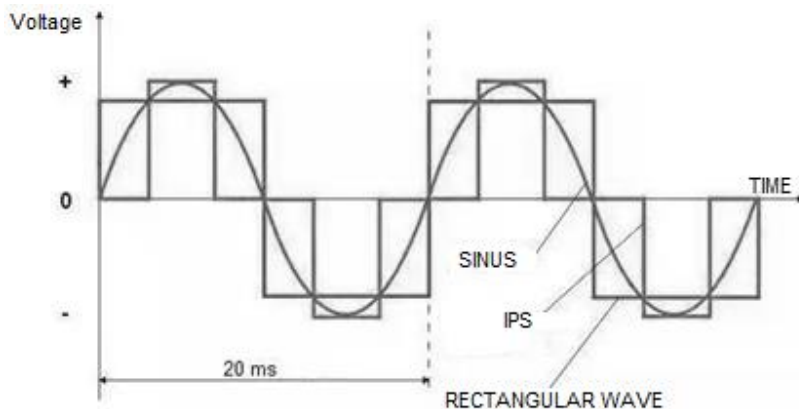

GENERAL INFORMATION ON SAFETY

THIS MANUAL IS INTEGRAL PART OF DEVICE. DON'T THROW IT AWAY, KEEP IT IN EASILY ACCESSIBLE PLACE AND GET KNOWN WITH IT'S CONTENT BEFORE FIRST STARTUP OF THE INVERTER.

- Don't expose inverter to direct rain, snow, dust, chemicals, oils etc.
- Don't cover the ventilation openings. Inverter should be installed in an easily accessible location with a minimum 30 cm of free space around the enclosure to ensure free circulation of the air, otherwise the unit may be exposed to overheating (minimum air flow rate is 145 CFM).
- To reduce the risk of fire or electric shock make sure that the existing wiring is in good condition and the wires have the correct parameters (cross-section, length etc.) Don't operate inverter with damaged or incomplete wiring.
- In the event of fire, use a fire extinguisher designed to put out fire on live electrical equipment in accordance with its operating instructions.
- This device contains components that may cause sparks. To avoid fire and / or explosion, do not install device near flammable materials, or in places where are non-fire devices. This includes any location where petrol powered machines, fuel tanks, connectors, binders, or other connections between fuel system components are stored.
- Do not open / remove housing from the inverter. The appliance does not contain any maintenance parts. Attempting to repair may result in electric shock or fire. Capacitors inside the device remain charged when the power is disconnected.
- Don't connect continuous and instantaneous loads greater than those specified in the unit's operating instructions.
- The inverter must be powered by a rechargeable battery or automotive electrical system (installation must have rechargeable battery)
- Don't charge battery (with rectifier, pulse generator, solar controller etc.) when inverter is connected and powered by the same battery, this type of connection may damage inverter and will invalidate the warranty (we recommend sinusPRO series models for this type of usage)

INSTALLATION OF THE DEVICE

Please observe the warnings and notes in the previous section during process of installation. In order to connect the device, first connect wires to the inverter and then according to the polarity (+ and -) connect them directly to the battery. Correct polarity of the input is very important and necessary, because reverse polarity may damage the inverter and void the warranty.

When installing the inverter, be sure to choose right battery (type and capacity) for direct connection of the device. Battery that is overloaded will have a much higher capacity than the one supplied by the manufacturer and will be instantly discharged or even damaged. We recommend using lead-acid batteries for continuous operation such as GEL, AGM or good quality acid deep discharge batteries rather than regular starter batteries.

TECHNICAL PARAMETERS

All SINUS inverters come with a range of safety features to ensure safe and trouble-free operation.

- Short-circuit protection
 - Thermal protection – switches off the device after about 60 - 70C
- Undervoltage protection – switches off the device if the input voltage is too low (discharge of the battery)
- Overvoltage protection – switches off the device when the overheated temperature is too high
- Overload protection – turns off the device when it is overloaded for more than dozen of seconds
 - Idle load – 300 mA

SINUS 600

Continuous power	300 W	300 W
Instantaneous (peak) power	600 W	600 W
Input voltage	10.5 V - 15.5 V	21 V - 31 V
Output voltage	225 V - 235 V	225 V - 235 V
Output voltage frequency	50 Hz (+- 2 Hz)	50 Hz (+- 2 Hz)
Efficiency at full load	> 92 %	> 92 %
Working temperature	0-40 C	0-40 C

SINUS 1000

Continuous power	500 W	500 W
Instantaneous (peak) power	1000 W	1000 W
Input voltage	10.5 V - 15.5 V	21 V - 31 V
Output voltage	225 V - 235 V	225 V - 235 V
Output voltage frequency	50 Hz (+- 2 Hz)	50 Hz (+- 2 Hz)
Efficiency at full load	> 92 %	> 92 %
Working temperature	0-40 C	0-40 C

SINUS 1600

Continuous power	800 W	800 W
Instantaneous (peak) power	1600 W	1600 W
Input voltage	10.5 V - 15.5 V	21 V - 31 V
Output voltage	225 V - 235 V	225 V - 235 V
Output voltage frequency	50 Hz (+- 2 Hz)	50 Hz (+- 2 Hz)
Efficiency at full load	> 92 %	> 92 %
Working temperature	0-40 C	0-40 C

SINUS 2000

Continuous power	1000 W	1000 W
Instantaneous (peak) power	2000 W	2000 W
Input voltage	10.5 V - 15.5 V	21 V - 31 V
Output voltage	225 V - 235 V	225 V - 235 V

Output voltage frequency	50 Hz (+- 2 Hz)	50 Hz (+- 2 Hz)
Efficiency at full load	> 92 %	> 92 %
Working temperature	0-40 C	0-40 C

SINUS 3000

Continuous power	1500 W	1500 W
Instantaneous (peak) power	3000 W	3000 W
Input voltage	10.5 V - 15.5 V	21 V - 31 V
Output voltage	225 V - 235 V	225 V - 235 V
Output voltage frequency	50 Hz (+- 2 Hz)	50 Hz (+- 2 Hz)
Efficiency at full load	> 92 %	> 92 %
Working temperature	0-40 C	0-40 C

SINUS 4000

Continuous power	2000 W	2000 W
Instantaneous (peak) power	4000 W	4000 W
Input voltage	10.5 V - 15.5 V	21 V - 31 V
Output voltage	225 V - 235 V	225 V - 235 V
Output voltage frequency	50 Hz (+- 2 Hz)	50 Hz (+- 2 Hz)
Efficiency at full load	> 92 %	> 92 %
Working temperature	0-40 C	0-40 C

SINUS 5000

Continuous power	2500 W	2500 W
Instantaneous (peak) power	5000 W	5000 W
Input voltage	10.5 V - 15.5 V	21 V - 31 V
Output voltage	225 V - 235 V	225 V - 235 V
Output voltage frequency	50 Hz (+- 2 Hz)	50 Hz (+- 2 Hz)
Efficiency at full load	> 92 %	> 92 %
Working temperature	0-40 C	0-40 C

WARRANTY CARD

DEVICE TYPE	
SALE DATE	
BUYER'S DETAILS (name etc.)	
SELLER'S DETAILS (company name etc.)	
SERVICE INFO (damage info etc.)	

FILL IN IF NEEDED

(*) Cross incorrect

I agree to pay the cost of inverter repair due to:

* expiration of the warranty period / * warranty void

Before proceeding with the repair, service will inform by phone about the exact costs of the repair.

Please attach a copy of the purchase document (receipt or invoice) to the complaint.

The full regulations of service repairs can be found on our website www.voltpolska.pl

Proper disposal of the product

(waste electrical and electronic equipment)

The marking placed on the product or in the texts related to it indicates that it should not be disposed of with other household waste at the end of its useful life. To avoid harmful effects to the environment and human health from uncontrolled disposal, please separate this product from other types of waste and recycle responsibly to promote the reuse of material resources as a continuing practice. For information on where and how to recycle this product in an environmentally safe manner, residential users should contact the retailer where they purchased the product, or their local government authority. Business users should contact their supplier and check the terms and conditions of their purchase contract. The product should not be disposed of with other commercial waste.

