

PRODUCT MANUAL

TOWER FAN

COMFORT 50

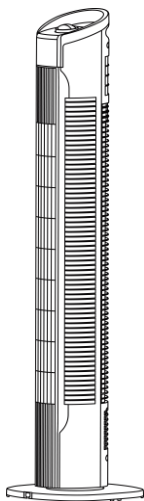

VOLT POLSKA Sp. z o.o.
ul. Bitwy pod Płowcami 76
81-771 Sopot
www.voltpolska.pl

Thank you for purchasing **tower fan COMFORT 50 by VOLT Polska**. Please read this user manual before starting the device.

IMPORTANT SAFETY INSTRUCTIONS



When using electric devices, basic safety precautions must be observed. To avoid the risk of burns, electric shocks, fire, and/or personal injury, please read the instruction manual carefully before using the device, and observe all of the instructions during the operation of the device.



GENERAL GUIDELINES

- Electronic devices are not toys! Keep children away from the device!
- Only use the devices for its intended purpose.
- The device is only suitable for use in private households and not for commercial use.
- Do not leave the device unsupervised while in use or connected to the mains.
- Switch off the device if it is not in use, in the event of malfunctions and for cleaning, and also remove the power plug.
- Do not carry the device by the power cord.
- Keep the device clean and dust-free.
- Never use the device outdoors.
- Check the device regularly for signs of visible damage. Do not use the device if you have determined damage, if the device has fallen down or if it does not function properly. Do not attempt to repair the device yourself.
- Repairs are only allowed to be carried out by qualified specialists.
- The power point must be located near to the device so that the plug can be removed easily in an emergency.



HAZARDS DUE TO ELECTRIC CURRENT

- The voltage stated on the name plate of the device must agree with the voltage of your mains electricity network.
- Only connect the device to a power socket that has been installed properly. Do not use a power strip or an extension cable.
- Never operate the device using a timer or another remote control device.

- Never touch the device, the power cable and the plug with damp or wet hands or if you are standing on wet ground.
- Do not place the power cord in the sink.
- Do not immerse in water.
- Immersing the device in water or other fluids leads to a risk to life of electric shock!
- Keep the device, the power cable and plug away from hot surfaces, naked flames, direct sunlight and sharp edges. When using the device make sure that the cable is not jammed (e.g. in doors).
- When you pull the plug out of the power socket, always pull on the plug and never on the cable.
- If the power cable of this device is damaged it has to be replaced by a correspondingly qualified person to prevent hazards. The same applies to the plug.



HAZARDS TO PEOPLE

- These devices can be used by children aged 8 years and above and by people with reduced physical, sensory or mental capabilities or a lack of experience and/or knowledge, if they are supervised or instructed in the safe use of the product and understand the hazards involved. Children must not play with the appliance.
- Cleaning and maintenance of the product must not be performed by children.
- Children do not recognise the hazards which can arise when handling electrical devices. Keep children away from the device. Pay particular attention when using the device if children are in the vicinity!
- Keep the packaging materials such as plastic bags and polystyrene parts out of the reach of children. Danger of suffocation!
- When laying the cable make sure that it cannot become a tripping hazard.
- Make sure that the device itself cannot be tripped over.

ARTICLE-SPECIFIC HAZARDS

- Make sure that the device isn't dirty and that it is assembled correctly
- Never operate the appliance on uneven surfaces or in the vicinity of steps. Avoid tipping the device over when it is in use (e.g. if there are borders on the floor).
- The pedestal fan may only be used, if it is fully assembled. Check all screw / plug connections at regular intervals. Re-tighten loose screws and ensure that plug connections are properly adjusted.

OVERVIEW OF APPLIANCE

1. Speed
2. Main Body
3. Power Plug
4. Stand
5. Screw

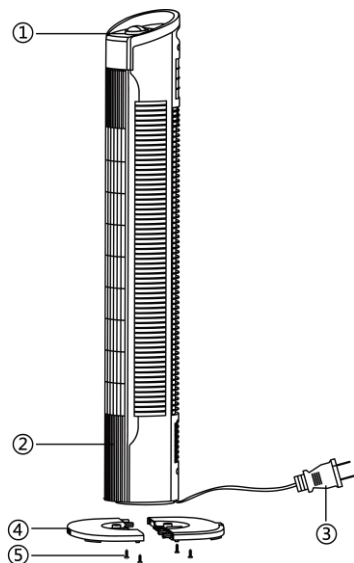

ASSEMBLING THE STAND

1. Take all of the appliance parts out of the packaging and remove all packaging materials and inserts.
2. Turn the fan upside down so that you can look at the holder. (Fig.1).
3. Take the power cord to cross the stand (4), see the methods by (Fig.2).
4. Fasten the stand (4), and press it into the outlet hole. (Fig.3)
5. Use 4 pieces of screw to tight up, see the methods by (Fig.4).

Fig. 1:

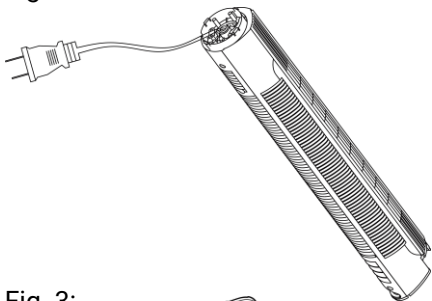

Fig. 2:

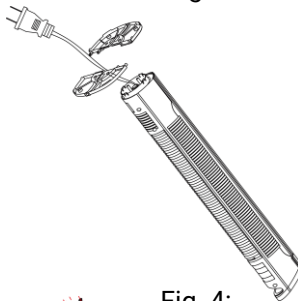

Fig. 3:

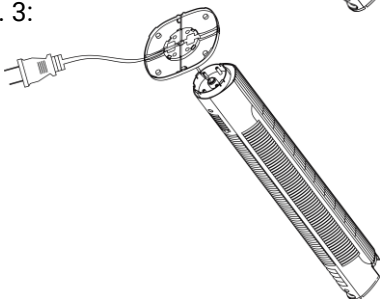
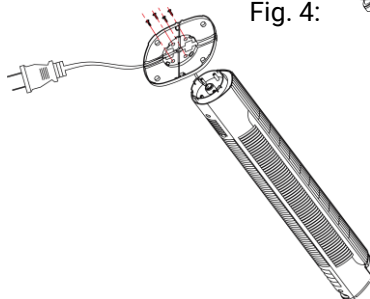
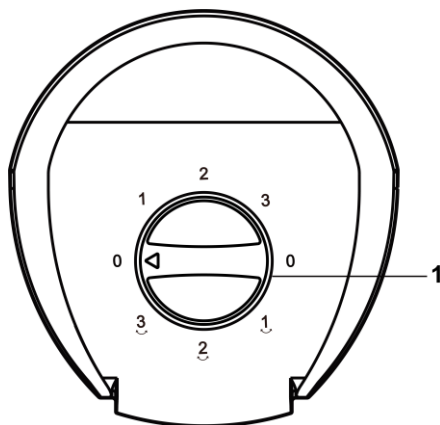

Fig. 4:



HANDLING THE APPLIANCE



SPEED

- Turn the button (1), to select the speed or with oscillation.
- 3 speed for select: (Low - Mid - High)

CLEANING AND MAINTENANCE

Before cleaning the appliance always disconnect the power plug from the receptacle.

- The appliance, the power cord and the power plug should not be immersed in water or other liquids when you are cleaning them. Clean them with a dry cloth.
- If it is very dirty, the outside of the appliance can be wiped carefully with a moist cloth and then dried carefully. Make sure that no moisture penetrates into the interior of the appliance.
- Do not use any harsh cleaners, steel brushes, scouring powder or other hard objects to clean the appliance as these can cause scratches on the surfaces.
- Clean the appliance regularly.
- Never use solvents, benzene or oil-based cleaners as these can damage the housing.
- Re-tighten visible screw connections on the appliance regularly in order to ensure that the device is functioning properly.

SPECIFICATION

POWER: 50W
VOLTAGE: 220-240V~ 50Hz
DIMENSION: 200mm/200mm/790mm
HEIGHT: 79cm
WEIGHT: 2kg

WARRANTY CARD

DATA OF PURCHASE	
SHIPPING ADDRESS	
SIGNATURE/STAMP	
DAMAGE DESCRIPTION	
SERVICE COMMENTS	

FILL IN IF NEEDED

(*) Cross incorrect

I agree to pay the cost of inverter repair due to:
* expiration of the warranty period / * warranty void

Before proceeding with the repair, service will inform by phone
about the exact costs of the repair.
Please attach a copy of the purchase document (receipt or invoice)
to the complaint.
The full regulations of service repairs can be found on our website
www.voltpolska.pl

